

Dimensions

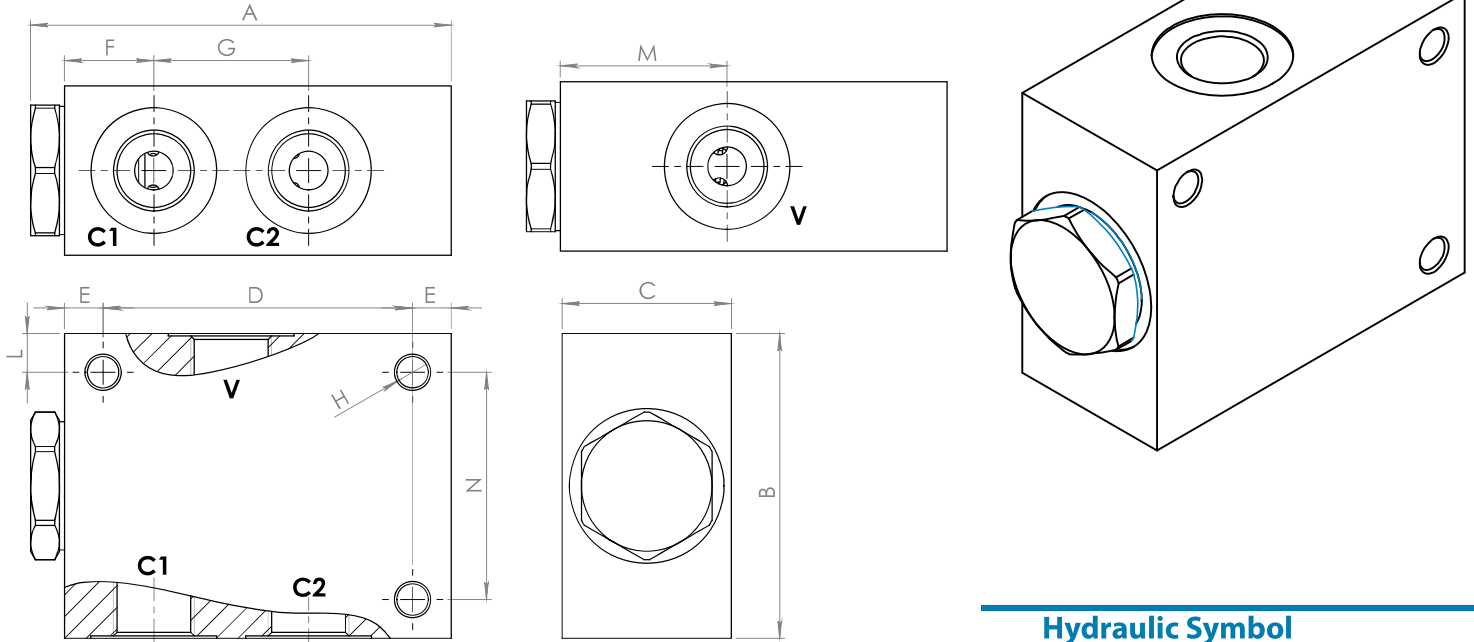

Size	C1 - C2 BSP	V BSP	A	B	C	D	E	F	G	H	L	M	N	Weight kg
02	3/8	3/8	87	63	35	64	8	18,5	32	6,5	8	34,5	47	0,52
25	3/8	1/2	87	63	35	64	8	18,5	32	6,5	8	34,5	47	0,51

Hydraulic Symbol

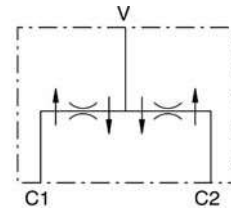

Curves

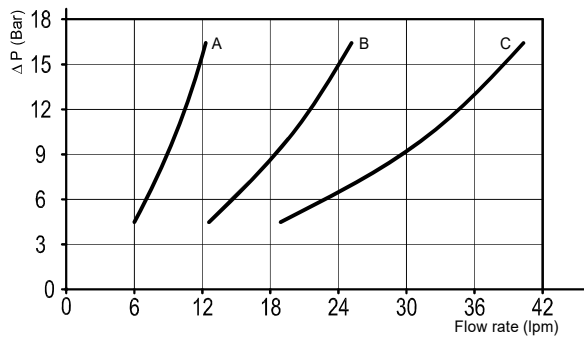

Features

Max Flow Rate (lpm)	38
Max Pressure (bar)	260
Slippage (top portion flow curve)	± 3%
Flow Division Ratio	50% - 50%

Materials: Aluminium manifold, hardened steel inner parts.

Ordering Code

FDC

--

-

Port Size BSP

02	3/8	3/8
25	1/2	3/8

Inlet Capacity (lpm)

A	6,5 - 12
B	13 - 23
C	24 - 38

Ordering Code Example: **FDC25B** - 1/2 - 3/8 BSP Ported Manifold, 13/23 lpm Inlet Range Capacity.